

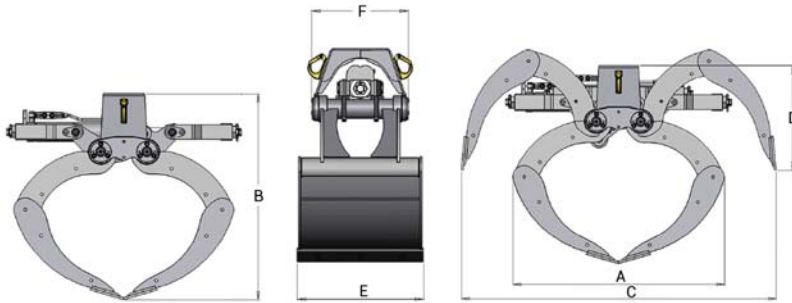

KEY FEATURES

- Double guide bars
- High pressure cylinder with double piston rod seals
- Pilot operated check valve
- 2 ton weld-on lifting hooks
- High tensile wear resistant steel cutting edges (500 HB)
- Reversible cutting edges
- Removable side plates



	TGO 500	TGO 650	TGO 800	TGO 900	TGO 1000	TGO 1200
A	1168	1168	1168	1168	1168	1168
B	1096	1096	1096	1096	1096	1096
C	1730	1730	1730	1730	1730	1730
D	678	678	678	678	678	678
E	600	660	800	900	1000	1200
F	498	498	498	498	498	498

MODEL SPECIFICATIONS



MODEL	Kg	m ²	Bar	l/min	kN	ton	tm
TGO 500	315	200	300	60	25	3	10
TGO 650	340	300	300	60	25	3	12
TGO 800	370	400	300	60	25	3	15
TGO 900	390	450	300	60	25	3	15
TGO 1000	405	500	300	60	25	3	15
TGO 1200	440	600	300	60	25	3	15