

KEY FEATURES

- Heavy duty
- Double guide bars
- High pressure cylinder with double piston rod seals
- High tensile wear resistant steel (400 HB)
- Extra reinforced body for rigid mounting - Excavator design
- Self lubricating bushings (not TG15 - 18DG)
- Reversible cutting edges
- High tensile wear resistant steel cutting edges (500 HB)
- Pilot operated check valve optional
- OPTIONAL ROTATOR
- See RMR Series

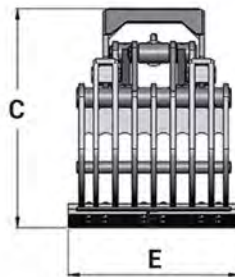
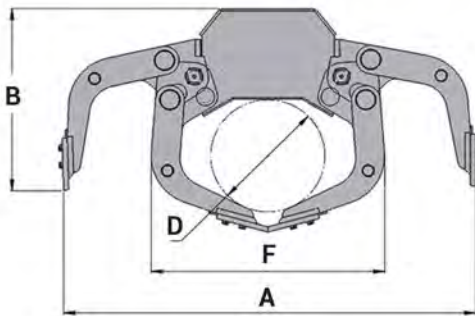

MODEL SPECIFICATIONS	WEIGHT Kg	GRIP m ²	PRESSURE Bar	FLOW l/min	CLAMPING kN	RIGID ton
----------------------	--------------	------------------------	-----------------	---------------	----------------	--------------

		TG 05 MP	TG 15 DG	TG 18 DG	TG 20 DG	TG 20 DGW	TG 25 DGL	TG 25 DG	TG 30 DG
		86	190	358	495	650	850	975	1465
		0.02	0.14	0.18	0.20	0.20	0.35	0.35	0.50
		250	250	250	320	320	320	320	320
		20	60	60	60	60	90	90	90
		12.4	17.5	18.5	33	33	57	57	69
		1-3.5	4-8	8-12	10-16	10-16	14-24	16-26	22-30
A		904	1154	1430	1556	1556	1936	1936	2347
B		457	535	632	737	737	893	893	1057
C		500	661	745	897	897	1095	1095	1297
D		-	315	370	430	430	530	530	650
E		300	390	532	532	680	800	800	1000
F		-	650	847	882	882	1085	1085	1330