

# ROTECH | INDEXATOR XR 300 - 600 H.D. VANE ROTATORS

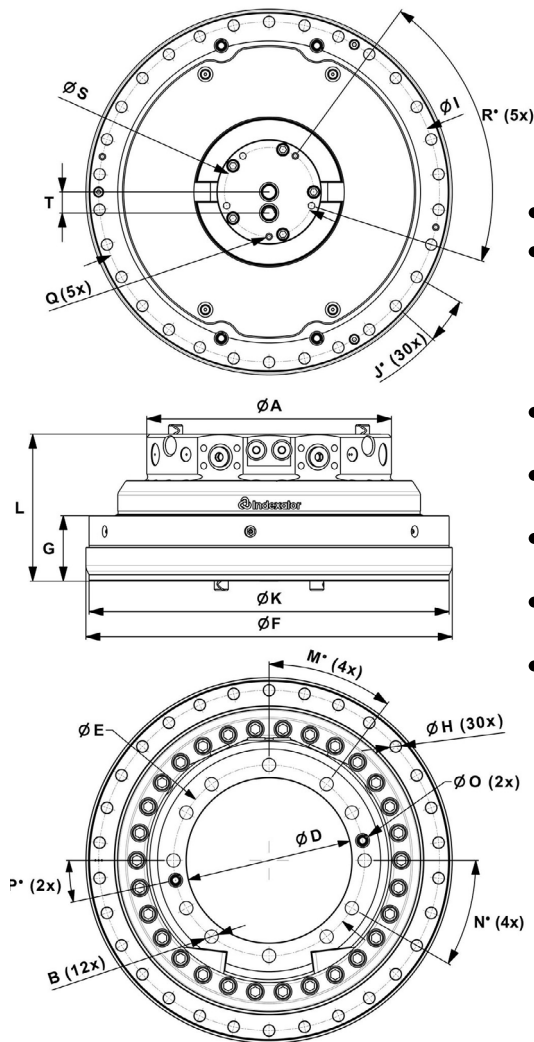
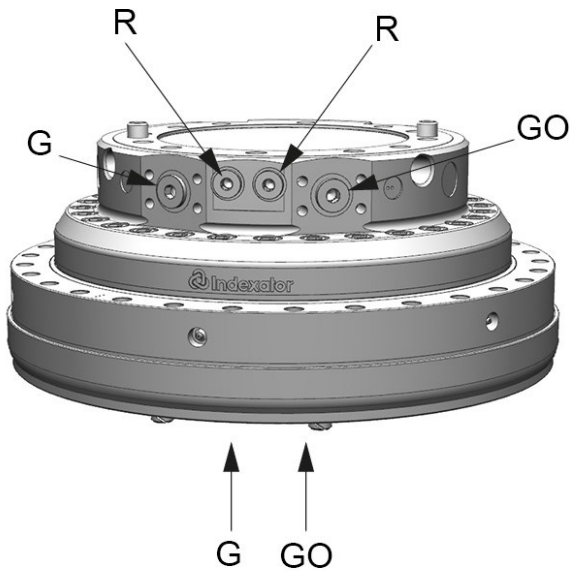

## XR Series

- Ultra Heavy Duty Vane Drive
- Rigid and Pendulum Mount

## KEY FEATURES

- Low maintenance
- Endless rotation
- High torque
- Ultra low profile
- Pressure limiting valves fitted

MODEL SPECIFICATIONS	WEIGHT Kg	STATIC ton KN	DYNAMIC ton KN	PRESSURE Bar MAX	FLOW l/min MAX	360° °	TORQUE Nm	PENDULUM ton	RIGID ton
XR 300	77	300	90	250	28	360°	3000	18-25	6-12
XR 350	121	500	150	250	35	360°	4350	-	14-20
XR 400	180	550	200	250	35	360°	4100	20-35	18-25
XR 500	216	700	250	250	40	360°	7000	-	25-30
XR 600	264	850	300	250	40	360°	7000	-	25-40

# INTERMERCATO

High performance lift and load attachments for Forestry, Transport, Construction and Recycling.

