

ROTECH / DEMOLITION RIGID MOUNT ROTATORS

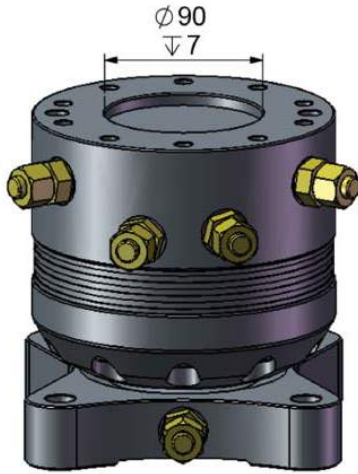

RMR 3

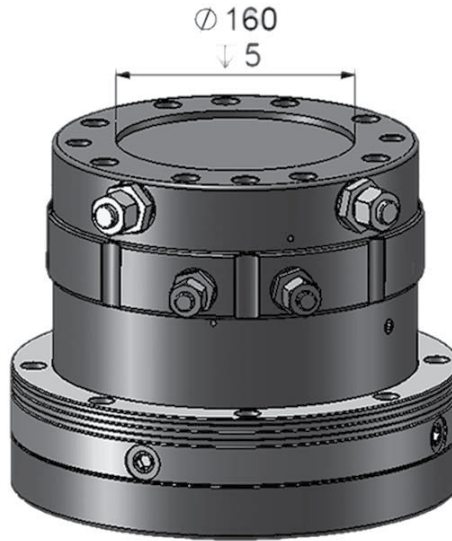

RMR 12

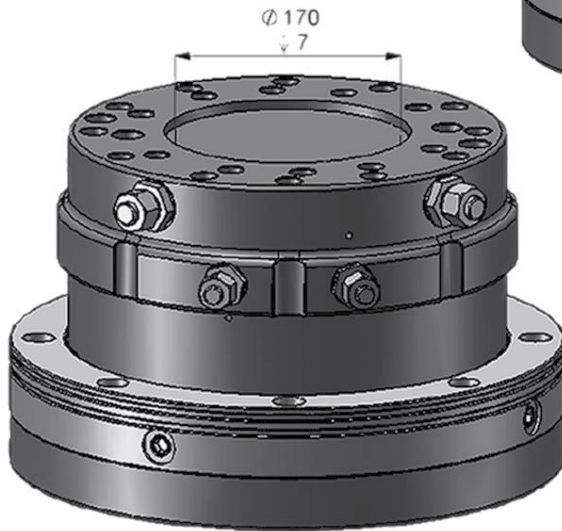

RMR 16C

RMR Series: G-rotor
(not designed to hold vertical items steady)

KEY FEATURES

- Fast operation
- Endless rotation
- High torque
- Steel flange for increased durability
- Ultra compact design
- High pressure construction
- Forged drive shafts & large tapered roller bearings resist high axial & radial loading.

MODEL SPECIFICATIONS	WEIGHT Kg	DYNAMIC ton KN	PRESSURE Bar	FLOW l/min	360°	TORQUE Nm	FITTINGS	PENDULUM ton	RIGID ton	BOTTOM FLANGE PCD	TOP FLANGE PCD	HEIGHT
RMR 2	20	2	320	22	360°	1100	3/8"	5	1-1.8	140/4	144/10	142
RMR 3	30	5	320	22	360°	1300	M18x1.5	10	1.8-3.5	140/4	144/10	188
RMR 6 C	50	7	320	25	360°	2600	1/5"	14	3-5.6	173/6	185/8	205
RMR 12	90	28	320	25	360°	4200	1/2'3/4"	25	6-12	270/8	210/10	228
RMR 16 C	150	38	320	25	360°	4200	1/2'3/4"	35	12-16	340/8	265/12	229